

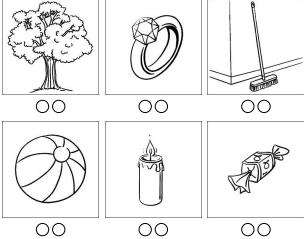

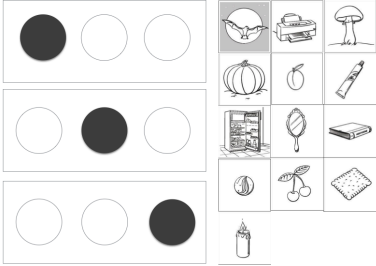
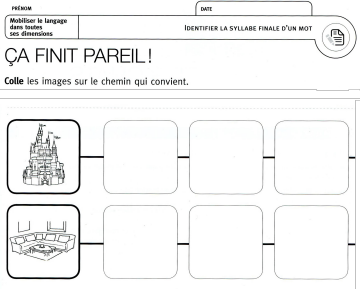

MON PLAN DE TRAVAIL 9S

SEMAINE 9

Lundi	Mardi	Jeudi	Vendredi								
Atelier 1 - Mobiliser le langage dans toutes ses dimensions - Phonologie.											
<p><i>Objectif : Coder les syllabes d'un mot. Localiser un son dans un mot.</i> Matériel : Ardoise ou feuille, crayon. Consigne : Je dis un mot, tu codes les syllabes de ce mot. Puis je te demande de colorier la syllabe ou tu entends le son A. (arbre, salopette, cobra, ananas, mandala, table, ordinateur, bateau, lavabo, panda, escalier, rat, camion, chat, balais, âne).</p> 	<p><i>Objectif : Localiser un son dans un mot</i> Matériel : fiches phono, crayon (niveau 2 à faire si niveau 1 ne pose pas de soucis) Consigne : Colorie la syllabe dans laquelle tu entends le son « B ».</p> <p style="text-align: center;"><small>Identifier et localiser des phonèmes dans un mot</small></p> <ul style="list-style-type: none"> • Un rond représente une syllabe. Colorie les syllabes si tu entends le « B » de bonbon. • Tu peux colorier plusieurs syllabes par mot. <p style="text-align: right;"><small>NIVEAU 1</small></p> 	<p><i>Objectif : Localiser un son dans un mot</i> Matériel : 1 boîte pour chaque codage de syllabe, les images mots. Consigne : Trie les mots selon si tu entends le son l au début à la fin ou au milieu du mot.</p> 	<p><i>Objectif : Identifier un son dans un mot. Associer des sons.</i> Matériel : Fiche « ça finit pareil », images mots ciseaux, colle. Consigne : Colle les images sur le chemin qui convient.</p> 								
Atelier 2 - Projet « La chenille qui fait des trous » - Mobiliser le langage, structurer sa pensée, explorer le monde, activités artistiques.											
<p><i>Objectif : Ecouter et comprendre une histoire. Restituer la chronologie d'un récit.</i> Matériel : https://www.youtube.com/watch?v=Sjii1O2fGLg&t=2s Consigne : Ecoute attentivement l'histoire puis raconte la à quelqu'un de ta famille en respectant la chronologie (jours de la semaine, fruits mangés).</p> 	<p><i>Objectif : Réaliser une composition plastique. Utiliser un objet : les ciseaux</i> Matériel : Ciseaux, fiches « tout un monde à créer », scotch, pic à brochette ou paille Consigne : Découpe les éléments de l'histoire et colle les sur les pics à brochettes ou des pailles pour mettre en scène ta propre histoire.</p> 	<p><i>Objectif : Mettre en scène une histoire, Utiliser des marionnettes, restituer la chronologie d'une histoire.</i> Matériel : marionnettes chenille et papillon, décors réalisés le mardi, de quoi filmer Consigne : Demande à quelqu'un de te filmer en train de raconter l'histoire avec les marionnettes et les décors</p> 	<p><i>Objectif : Reconnaître les jours de la semaine. Associer les différents éléments de l'histoire.</i> Matériel : ciseaux, colle, fiche jours de la semaine. Consigne : Je colle les étiquettes qui correspondent à l'histoire sous chaque dessin</p>  <table border="1" data-bbox="1715 1433 2175 1517"> <tr> <td>jeudi</td> <td>samedi</td> <td>dimanche</td> <td>lundi</td> </tr> <tr> <td>jeudi</td> <td>samedi</td> <td>dimanche</td> <td>lundi</td> </tr> </table>	jeudi	samedi	dimanche	lundi	jeudi	samedi	dimanche	lundi
jeudi	samedi	dimanche	lundi								
jeudi	samedi	dimanche	lundi								

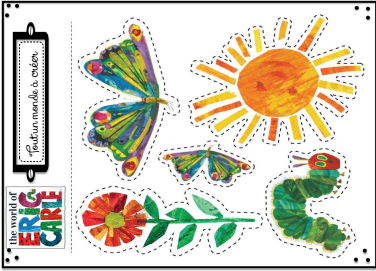
Identifier et localiser des phonèmes dans un mot

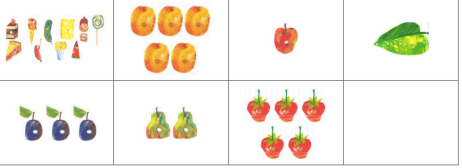
- Un rond représente une syllabe. Colorie ces syllabes si tu entends le « B » de bonbon.
- Tu peux colorier plusieurs syllabes par mot.

NIVEAU 1

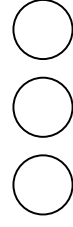
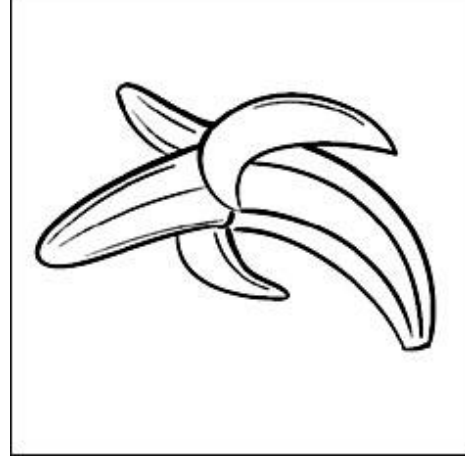
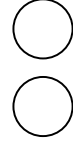
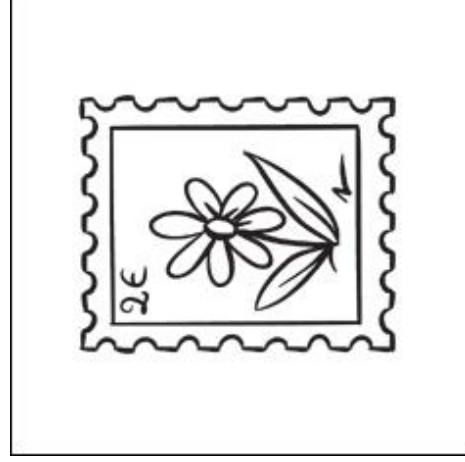
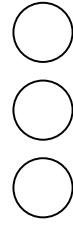
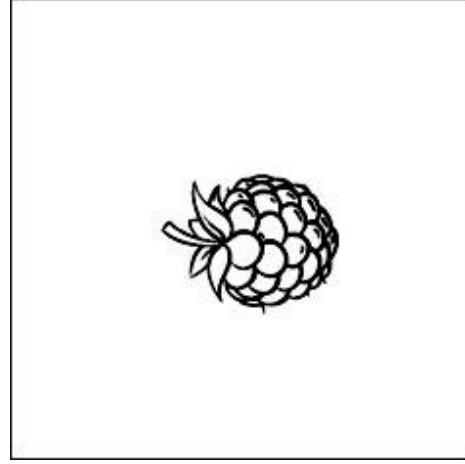
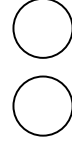
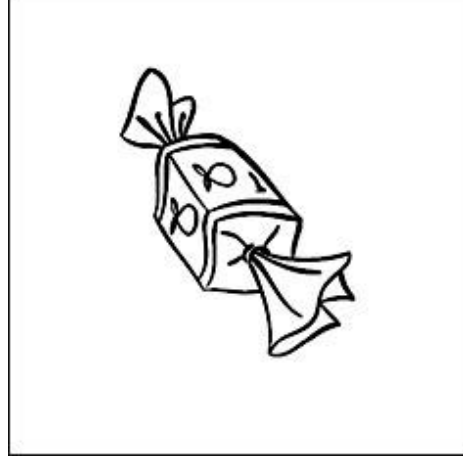
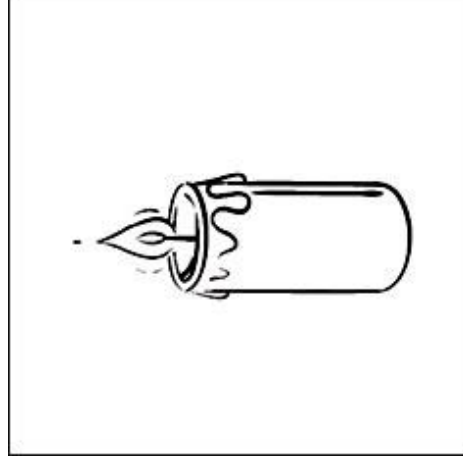
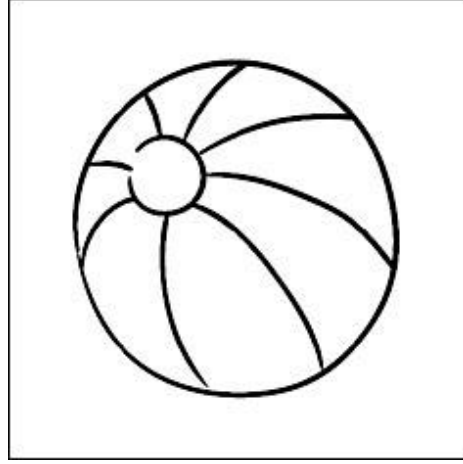
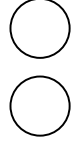
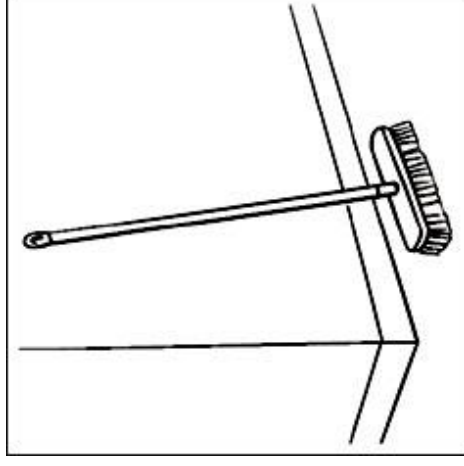
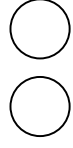
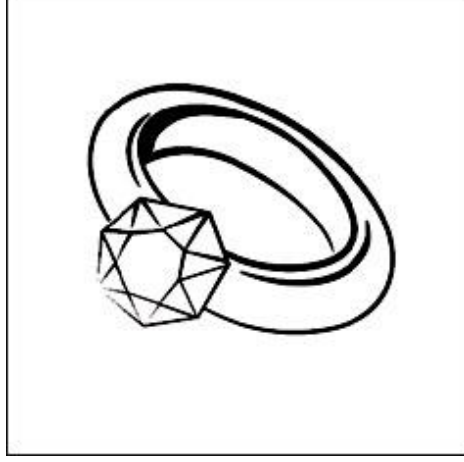
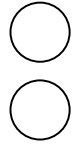
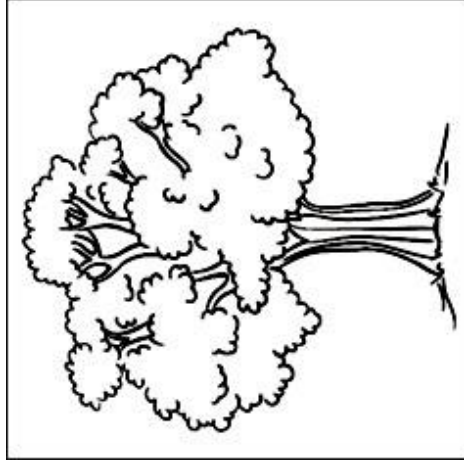

Identifier et localiser des phonèmes dans un mot

- Un rond représente une syllabe. Colorie ces syllabes si tu entends le « B » de bonbon.
- Tu peux colorier plusieurs syllabes par mot.

NIVEAU 2

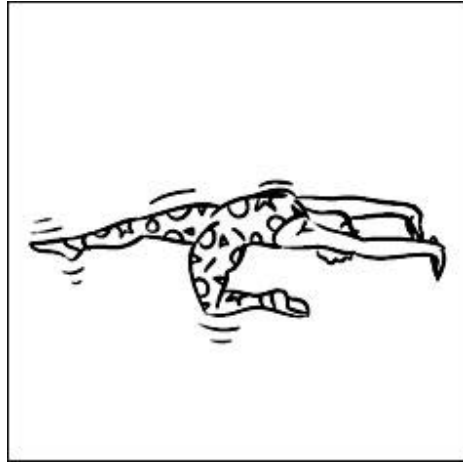
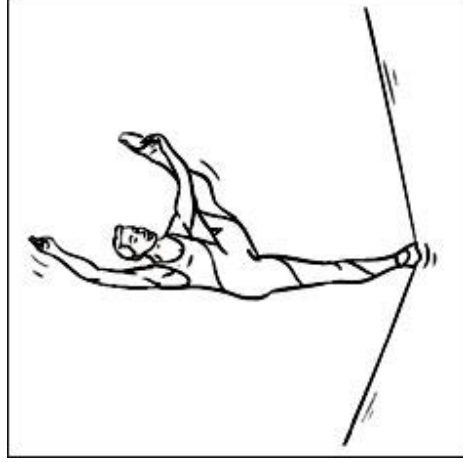
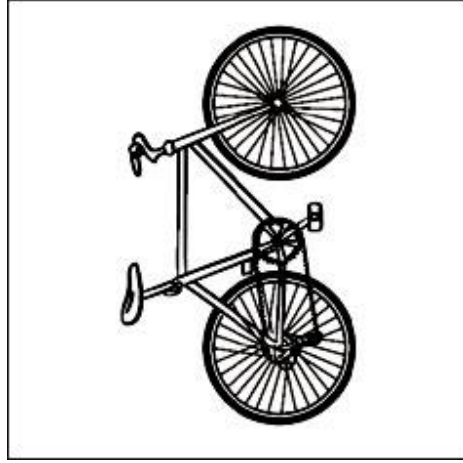
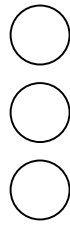
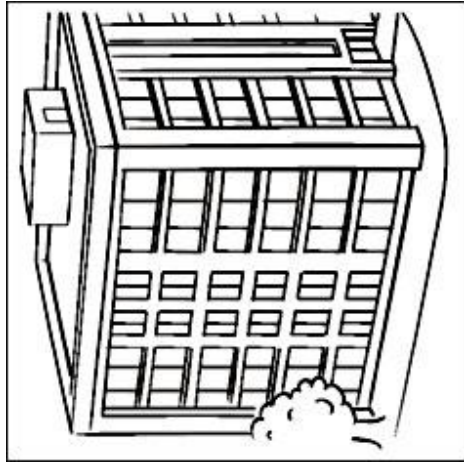
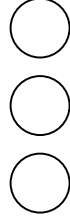
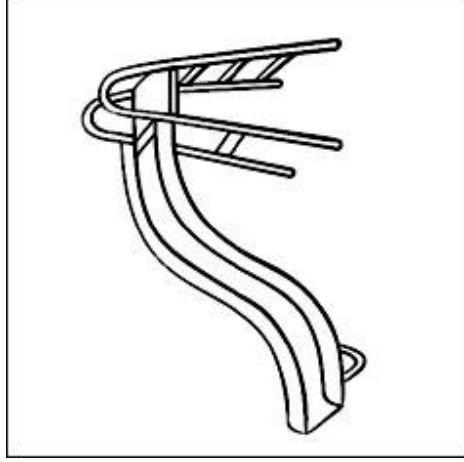
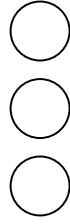
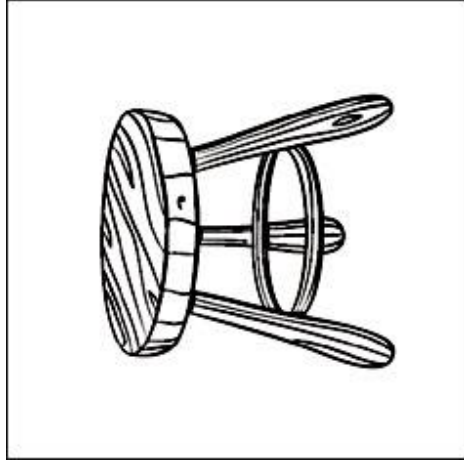
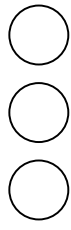
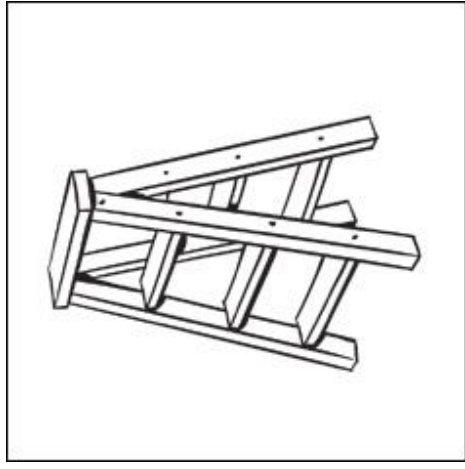
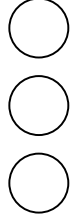
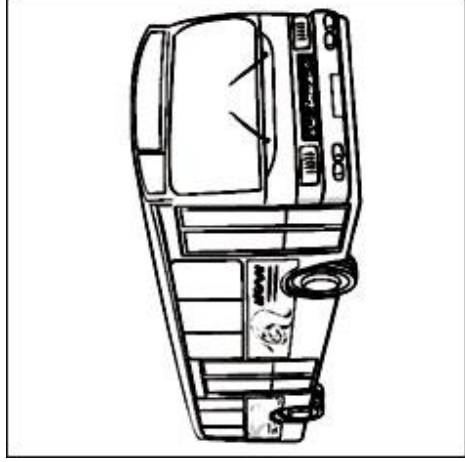
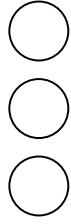
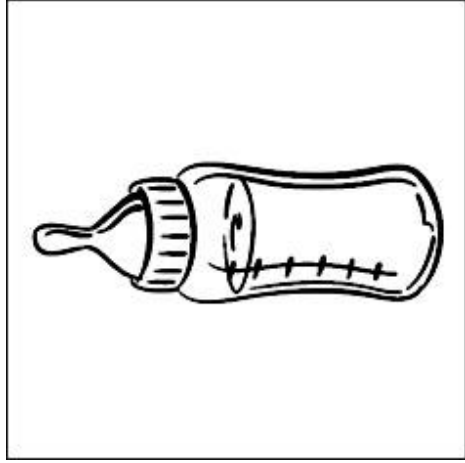

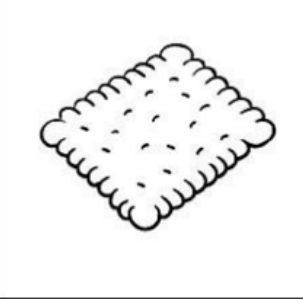
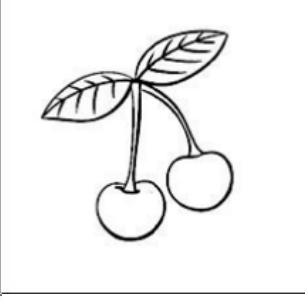
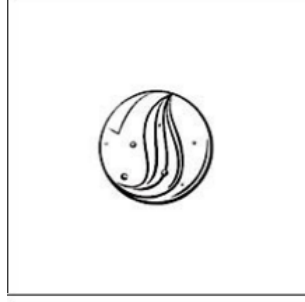
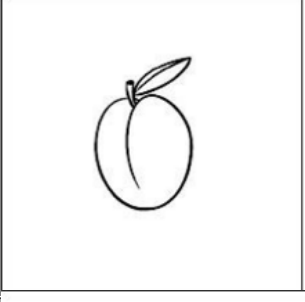
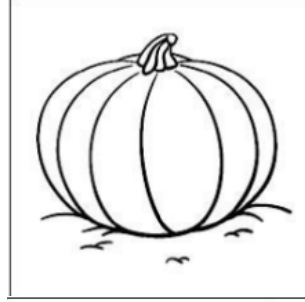
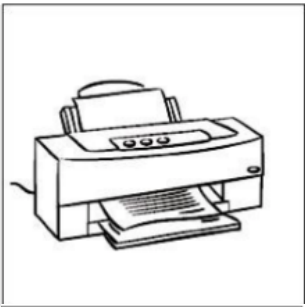
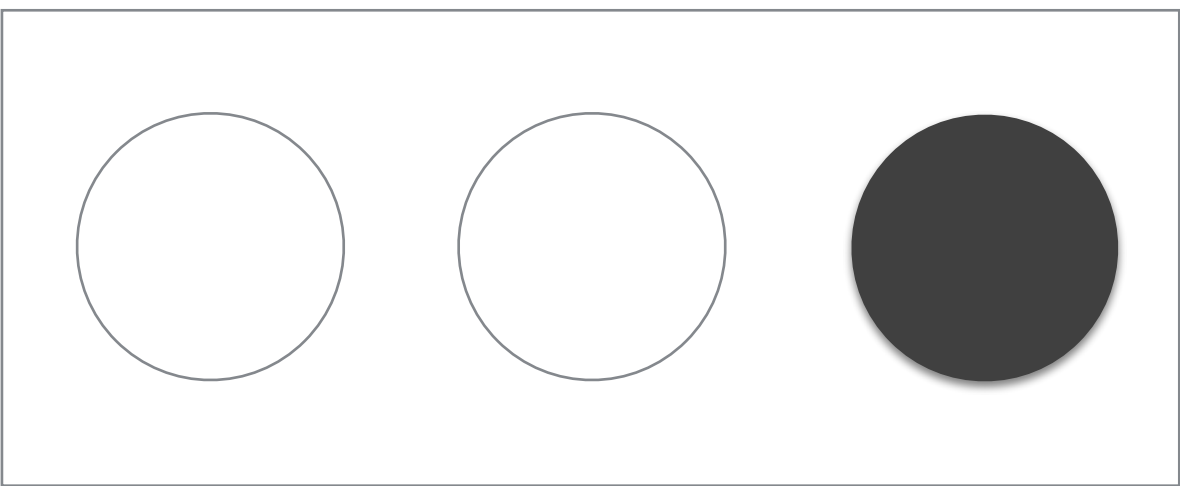
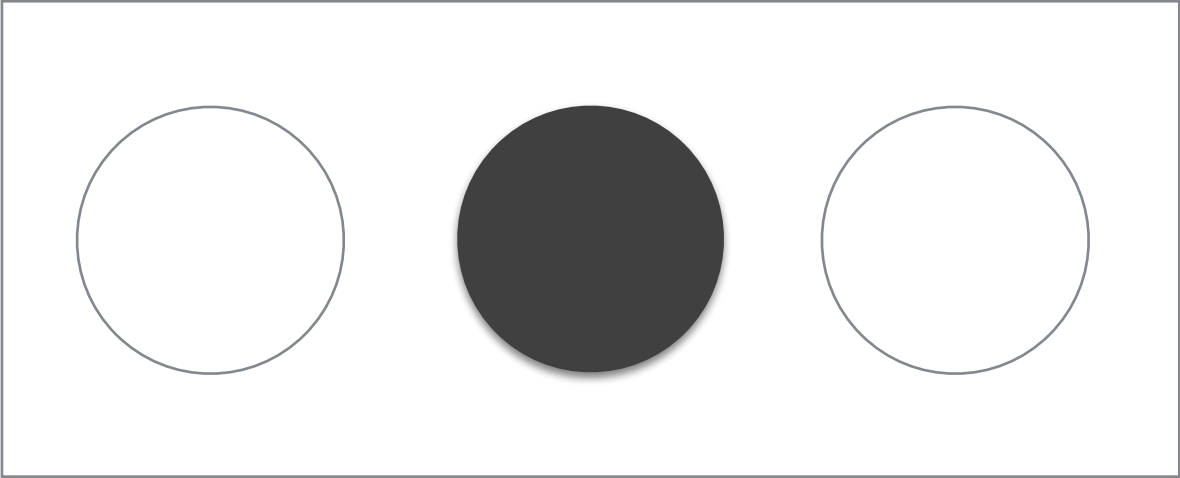
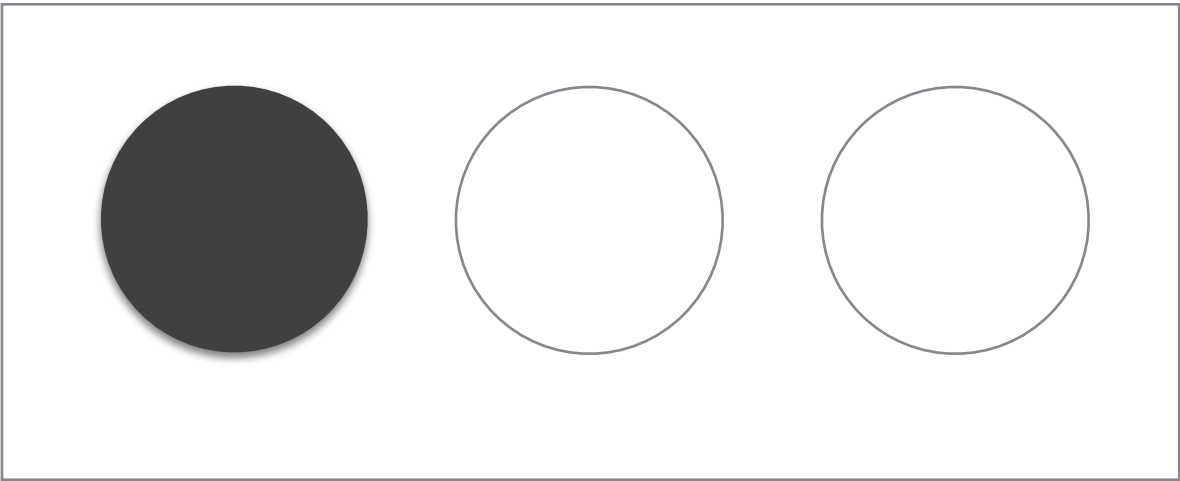

PRÉNOM

DATE

Mobiliser le langage
dans toutes
ses dimensions

IDENTIFIER LA SYLLABE FINALE D'UN MOT



ÇA FINIT PAREIL !

Colle les images sur le chemin qui convient.

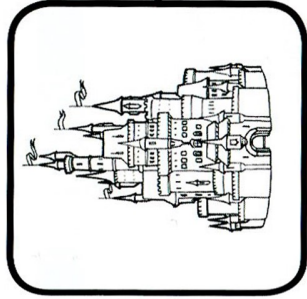

CHATEAU

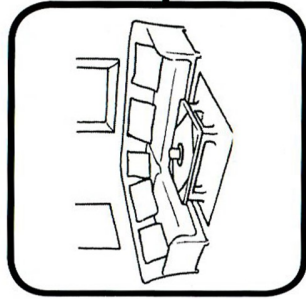

SALON

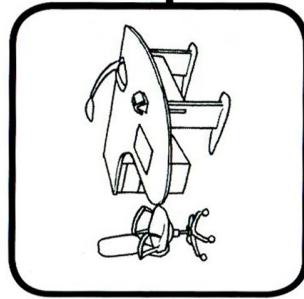

BUREAU

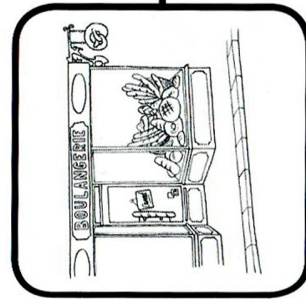

BOULANGERIE

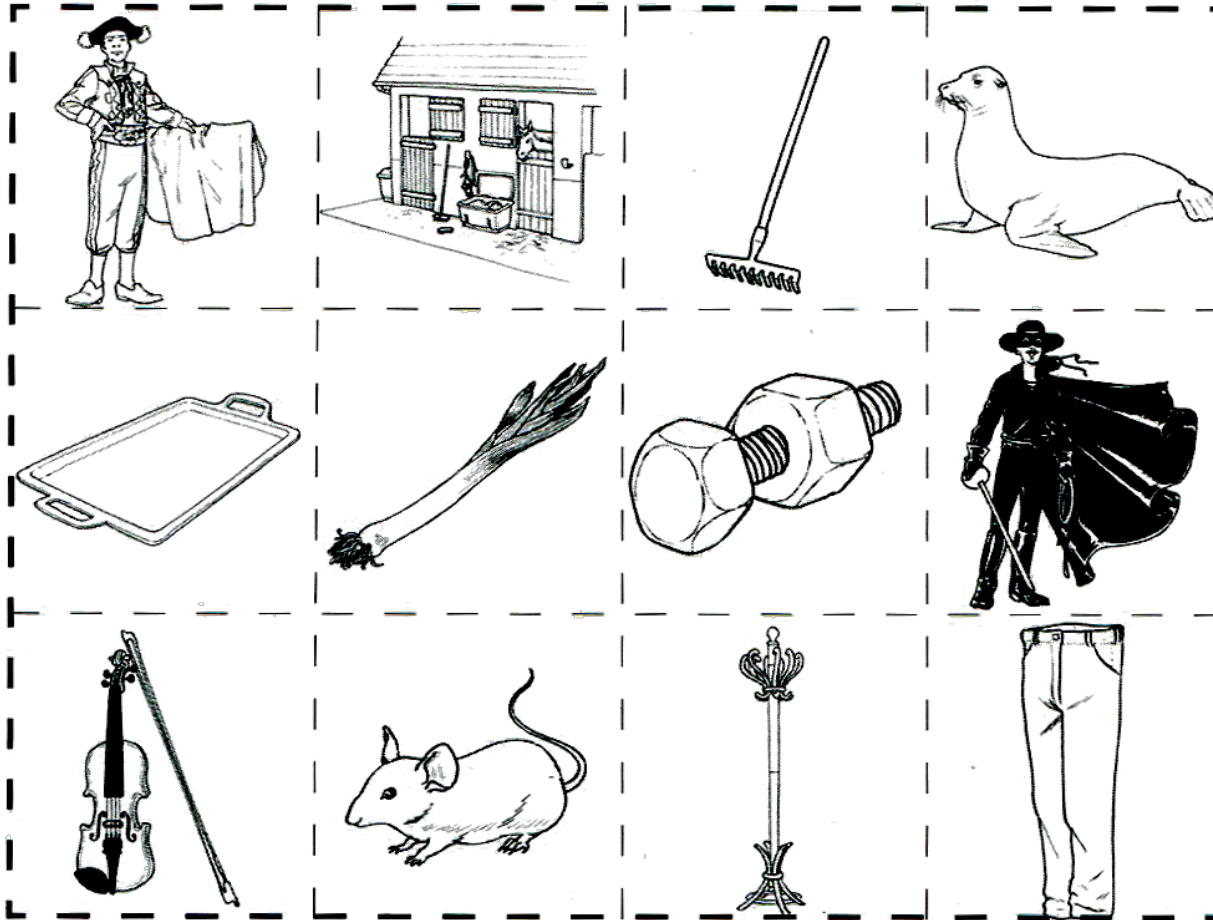

TORERO
 PLATEAU
 VIOLON

ECURIE
 POIREAU
 SOURIS

RATEAU
 BOULON
 PORTE MANTEAU

OTARIE
 ZORO
 PANTALON

Fait un monde à créer

the world of
**ERIC
CARLE**

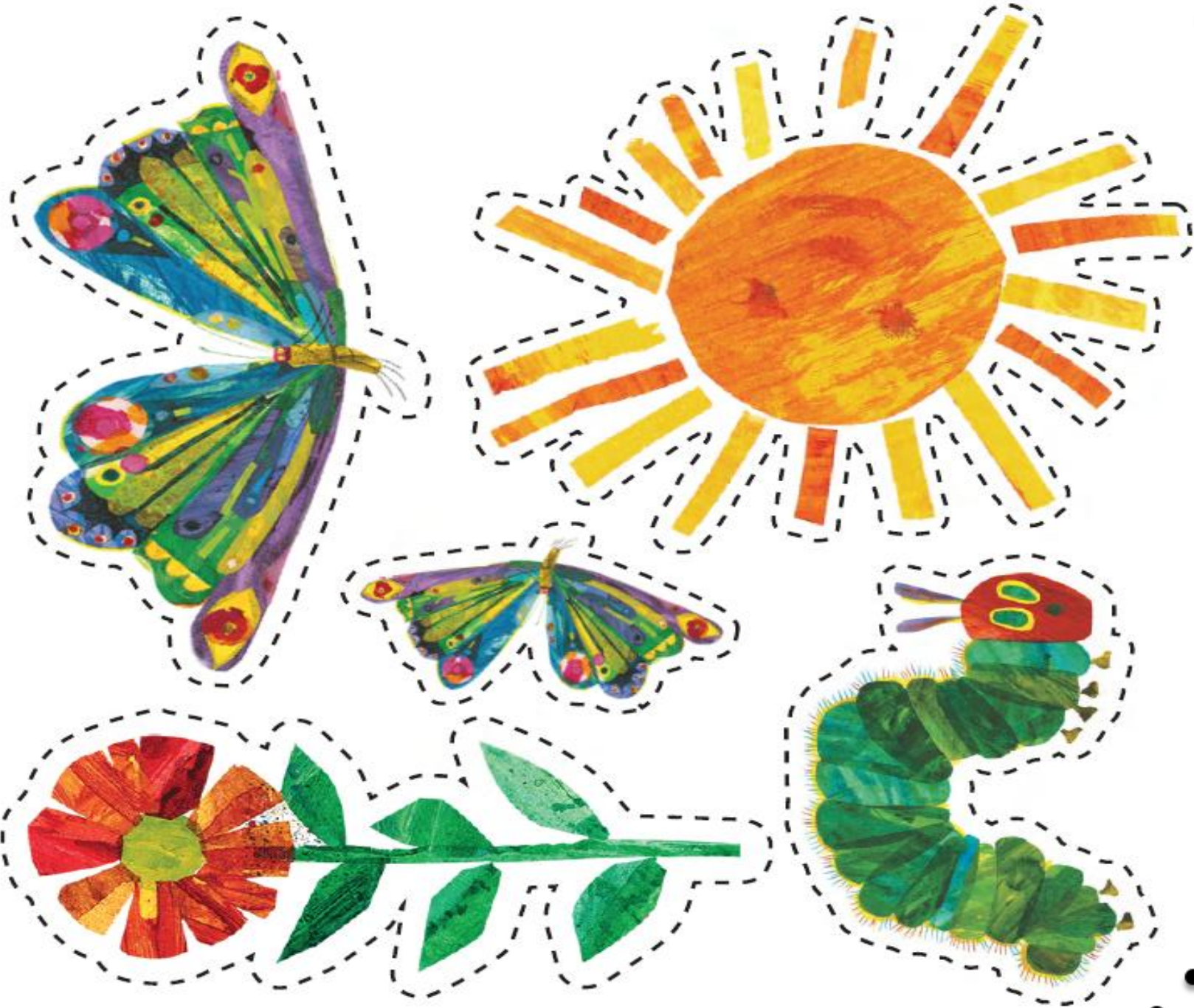







A toi...



Découverte du monde : connaître les jours de la semaine ; faire correspondre l'alphabet en capitale / script / cursive

Consigne : Je colle les étiquettes qui correspondent à l'histoire sous chaque dessin.

	Elle croque dans une pomme.	
	Elle croque dans deux poires.	
	Elle croque dans trois prunes.	
	Elle croque dans quatre fraises.	
	Elle croque dans cinq oranges.	
	Elle a mal au ventre.	
	Elle croque dans une feuille.	

jeudi	samedi	dimanche	lundi
<i>jeudi</i>	<i>samedi</i>	<i>dimanche</i>	<i>lundi</i>

mardi	vendredi	mercredi
<i>mardi</i>	<i>vendredi</i>	<i>mercredi</i>